

Nursing Assist Module Compact Patient Monitoring System Using Iot Application

Dr. R. Kishore Kanna¹, Dr. Sudharani B Banappagoudar*², Dr. Helen Shaji J.C³, Dr. Ponnu Kangeswari⁴, Dr. V. Uma⁵, Dr. Manisha Gupta⁶

Assistant Professor^{1,5}, Professor², Principal^{3,4,6}

Department of Biomedical Engineering¹

School of Nursing Sciences²

Medical Surgical Nursing^{4,5}

Vels Institute of Science, Technology & Advanced Studies¹

ITM University, Gwalior (MP)²

Shri Sathya Sai College of Nursing (Off Campus, Chennai), Sri Balaji Vidyapeeth University³

Driems School & College of Nursing Tangi Cuttack, Odisha⁴

Mother Theresa post graduate and research institute of health sciences, Puducherry⁵

Rabindranath Tagore University Institute of Nursing, Bhopal⁶

Orcid: 0000-0002-8004-1501, 0000-0002-7259-769X, 0000-0003-4358-1856

kishorekanna007@gmail.com sudharani.sons@itmuniversity.ac.in

DOI: 10.47750/pnr.2022.13.S08.36

Abstract

Many sectors now embrace the concept of a digital environment where various kinds of sensors and local processors are linked to exchange information. These concepts have been used to build a variety of goods. The healthcare sector is one where many advancements are being made. The majority of illnesses may be prevented and treated with the help of medications. By taking the right medications, many dangerous and dangerous disorders may be healed. The suggested system includes an IoT-enabled medication reminder system that notifies patients when it is time to take their medications which makes the nursing practices to support healthcare needs quite easy and efficient. By giving audio-visual alert, it reminds the patient to take their medications at the appropriate time. The system aids in keeping track of the patient's medical information and medication administration.

Keywords: Nursing station, Clinical Support, Patient monitoring, Arduino, IOT, Medical Alert System.

Introduction

One of the most rapidly expanding industries that has the potential to alter how people live their everyday lives is the internet and embedded systems [1]. The goal of embedded devices is to create a distinctive computer system. In most cases, an embedded system just performs one operation. However, these internet-connected embedded devices may converse through another network equipment [2]. Additionally, these gadgets provide flexibility and amenities to enhance the living space. Through IoT (Internet of Things) characteristics, people have the ability to remotely manage and monitor the gadgets [3]. Hospitals have systems in place to monitor patients continuously. Their heartbeat and ECG are regularly analysed. When they go home, there is no provision for checking the parameters [4]. Additionally, it is not necessary for several medical professionals to be physically present with patients in order to check on the health of coma patients; instead, it is intended to remotely monitor the health of any individual [5]. The health care system has recently advanced to provide people better facilities, and technology has played a significant part in this marathon of development. One's lifestyle always makes life simpler for them. The use of technology to monitor patients' health benefits both patients and healthcare professionals. For a patient with a chronic illness, there are several health markers that need to be continuously monitored, whether in a hospital setting or at home [6]. Body temperature, pulse, heart rate, respiration rate, and other measurements should be among these parameters. Every patient in a hospital has a monitor mounted to their bedside for

continuous vital parameter monitoring. Any changes in the parameters that a layperson would be unable to notice due to this design must be manually checked, necessitating the involvement of a healthcare professional [7]. This has been the fundamental flaw of traditional health monitoring up until recently, therefore the addition of the IOT (internet of things) to the system would be beneficial to patients and healthcare professionals alike. It is a centralised system that offers wireless patient data transfer using sensors, software, and data exchange via the internet.

Literature Survey

Researchers used the Raspberry Pi in a cloud-based system to track body temperature. Pi captures temperatures and transmits them wirelessly to cover a greater area of patients using wireless sensor networks (WSN). The collected data is then added to and presented on the website used to store the data [8].

Researchers in academia present a system that uses a microcontroller and a ZigBee module to detect body temperature. Information is gathered using a variety of sensors that are connected to the microcontroller. Additionally, attached to the microcontroller is a ZigBee module, which allows data to be sent to the specified receiver [9].

A small number of researchers utilise the LM-35 to track body temperature. The Arduino board is attached to the temperature sensor. The SQL database format of the Arduino board is linked to the website. The website receives the sensor readings. Anyone can keep an eye on the weather from wherever [10].

Engineers tracked and monitored patient body temperature, pulse rate, ECG wave, and even the patient's posture using an ARM cortex M4F micro controller. An Android app was also developed to track the patient's health. Microcontroller and Android phone connections are made through Bluetooth [11].

A system that monitors a patient's temperature, blood pressure, and heart rate was developed by researchers. All of the sensors were interfaced with the ATmega 32, which is what is utilised for this. In the event of any irregularity, a GSM module is utilised to create SMS notifications. If the value is low after data collection, an SMS is sent to the doctor [12].

In this article, researchers suggest a system that employs a variety of methods to keep an eye on people who are old or incapacitated. The data obtained from sources like smart metres, equipment use, and video surveillance is subject to a variety of statistics mining approaches. The best models for M-Health care prediction to provide precise human activity recognition are proposed to be random forest and VSM [13].

This article describes a proposed project that uses temperature and pulse rate sensors to measure the body temperature and pulse rate, two vital parameters for patients with severe illnesses. so that the doctor can keep an eye on things and respond right soon if necessary [14]. The doctor is informed if the situation necessitates it so that he may begin treating the patient right away.

It offers a touchscreen application that is very user-friendly for carrying out all actions. By using AT (assistive technology), personal activities and independence may be better controlled and achieved. However, since it is expensive, there is a lack of training, it is not readily available, and very few people are aware of it. 2 billion individuals will need at least one assistive device by 2050, according to a poll. The elderly may need two or more assistive goods at once [15].

They describe how to use open-source technologies to create and deploy assistive technology devices. This offers a fresh method of controlling drug amounts. As the primary controller, they utilised an Arduino Mega 2560. There are additional options for taking the medication thanks to this helpful technology [16]. It is based on an automated alarm system that employs a GSM network-connected interface and notification system. a pillbox modelled after the MCS-51

In order to further advance the standard of living for people, computers must be connected to things in the physical world, according to Kevin Ashton, who initially proposed the concept of the Internet of Things (IoT) in 1999. IoT, which is still a developing industry, has the potential to significantly alter how we live. IoT will link individuals and machines, resulting in a more connected way of living [17].

According to this research, older people need to take various drugs since their physical and, in rare instances, mental abilities are deteriorating. In light of this, the idea of an IoT-Based Smart Medicine Reminder Device will be an excellent business potential [18].

SYSTEM ARCHITECTURE

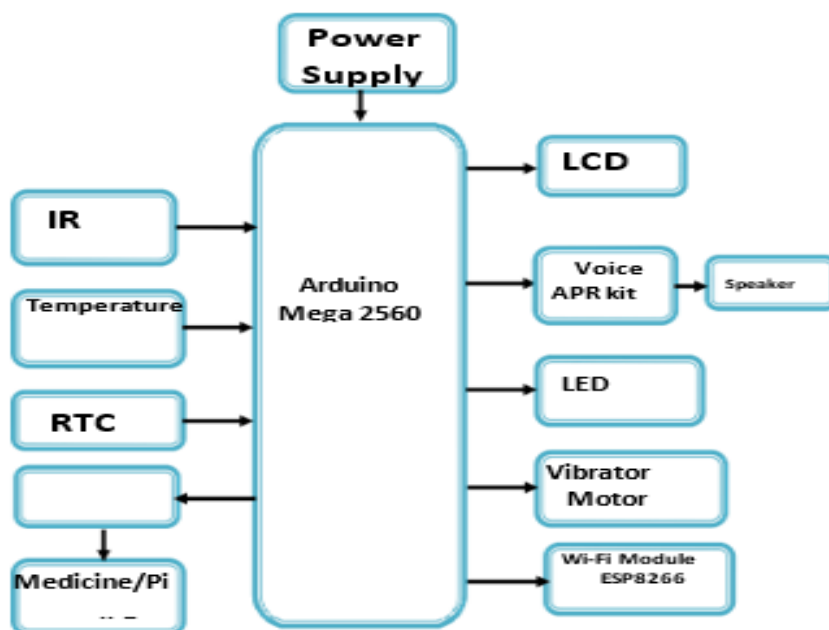

Fig 1. System Architecture

The pill box that makes up the medication reminder system has a number of sections. Its layout makes it simple for regular folks to utilise for their medicine. LEDs are used in the pill box's control system to visually warn patients when they need to take their medications. The device has a buzzer that sounds an audible alarm to the patient. It will buzz for a certain period of time, and the patient must press the key during that time to take the medication. If not, a GSM alert will notify the patient's caregiver that the patient has not taken the medication at the time instructed by the doctor. At the appointed time selected by the keeper, the buzzer and LEDs sound the alarm.

The suggested system's block diagram is shown above:

Three sensors are permanently installed in the system to track patient health. They are Perspiring

For monitoring the patient's temperature and heartbeat, a probe, temperature sensor, and heartbeat sensor are used, respectively. The microcontroller will receive the output in analogue form from the temperature sensor LM35 and the sweating probe, and the results will be presented on a website created for monitoring purposes. The heartbeat sensor's output will be in digital form, and it will also be sent to the microcontroller. The heartbeat value will then be shown on a specially created webpage. A warning that the patient's health is not good will be sent to the patient's caregiver through SMS if the value exceeds the reference values specified in the programme.

The RTC DS307 is connected to the Arduino through the I2C interface, keeping track of timings for medical purposes. It has the potential of automated changeover in the event that the power fails for whatever reason. The patient will see the name of the medication on the system's LCD. The patient may push a confirmation key connected to the microcontroller to give digital output when the medication is taken.



Fig.2. Flowchart for the System

Conclusion

This technique prevents patients from receiving the incorrect dose while also keeping them safe. The effort required by the patient and the patient's caregiver to remember their medications will be reduced, and the patient will get an alert when their drug is due.

Reference

- [1] Murarishetty S, Goud GD, Chinababu M, Jagadish A. Paralysis Patient Health Care Monitoring System Using IoT. *Technix International Journal for Engineering Research*. 2022 Jun 24;9(6):59-62.
- [2] Logeshwaran J, Malik JA, Adhikari N, Joshi SS, Bishnoi P. IoT-TPMS: An innovation development of triangular patient monitoring system using medical internet of things.
- [3] Dixit S, Vasupradha S, Todurkar SV, Harshitha KS, Alekhya O. Air Pollution Control Using IoT: A Survey. In *Proceedings of Third International Conference on Intelligent Computing, Information and Control Systems 2022* (pp. 585-599). Springer, Singapore.